

HIGH VOLTAGE RESIDENTIAL ENERGY STORAGE



HV RESS-72: 204.8V~409.6V 72Ah (14~29KWH)

HV RESS-100: 204.8V~409.6V 100Ah (20~40KWH)



SAFETY

- + Long life type prismatic LiFePO4 cells, suitable for energy storage application.
- + Low voltage system, safety for application.
- + Cell certification: UN38.3, ROHS, IEC62619, UL1973 and UL9540A
- + Battery certification: UN38.3, MSDS, CE

DESIGN

- + Stacked structure, easily installation.
- + -20~+55°C widely temperature range.
- + Maintenance free.
- + Cycle life >6000 cycles.

SCALABILITY

- + Parallel support for more energy.
- + Max. 50A charge/discharge current.
- + Free wiring between modules.

BATTERY MANAGEMENT SYSTEM

- + Independent protection for charge and discharge.
- + SOC, SOH display and PC software for detailed operation.
- + OVP, LVP, OCP, OTP, LTP protection.
- + CAN communication port for inverter.
- + 2* Dry output port and 1* Dry input port.

HV RESS- 72

SPECIFICATION

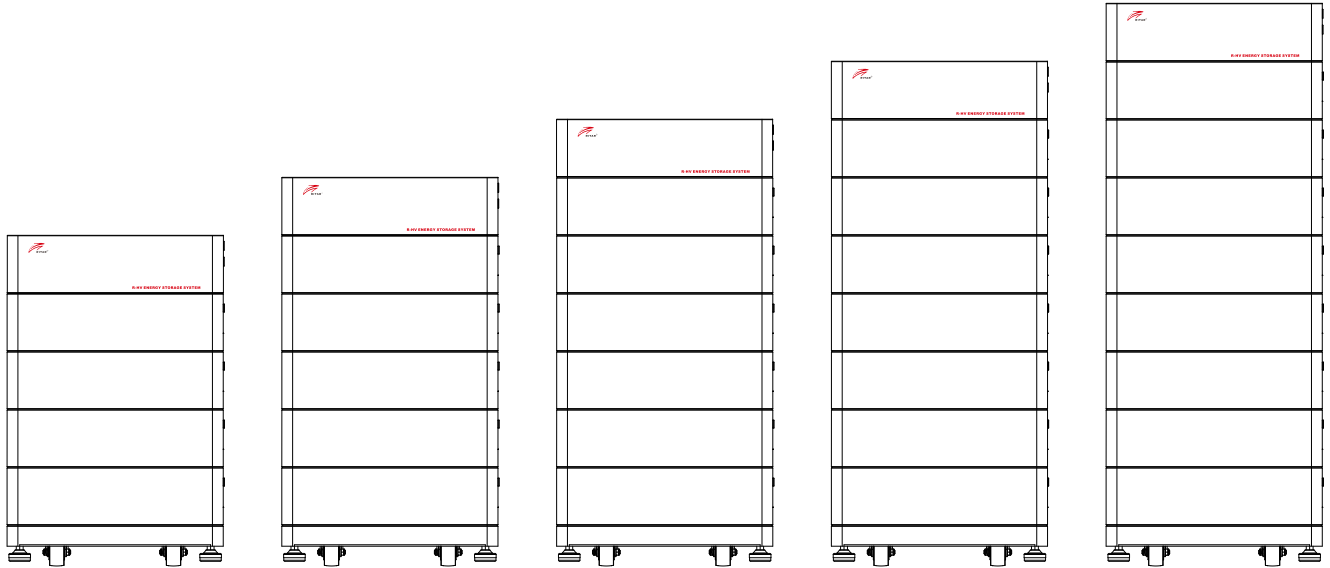

Battery Module	51.2V 72Ah (3.68KWH)				
Number of Battery Modules	4	5	6	7	8
Total Energy [kWh]	14.7	18.4	22.0	25.7	29.4
Nominal Voltage [Vdc]	204.8	256	307.2	358.4	409.6
Voltage Range [Vdc]	160~240	200~300	240~360	280~420	320~480
Max. Charging Current [A]	50	50	50	50	50
Max. Discharging Current [A]	50	50	50	50	50
Pulse Discharge Current	100A/10s	100A/10s	100A/10s	100A/10s	100A/10s
Max Inverter Power [W]	10000	12800	15360	17920	20480
Dimension (W*D*H, mm)	600*450*910	600*450*1070	600*450*1230	600*450*1390	600*450*1550
Operating Temperature Range	Charge: 0 ~ +55°C; Discharge: -20 ~ +55°C				
Operation Humidity	0~95% RH (No condensing)				
Weight [Kg]	Battery Module: 35.0Kg/pcs Base: 16.5Kg/pcs, Top Case: 10.0Kg				
Designed Calendar Life	10 years				
Communication interface	CAN*1, DI *1, DO*2				

HV RESS- 100

SPECIFICATION

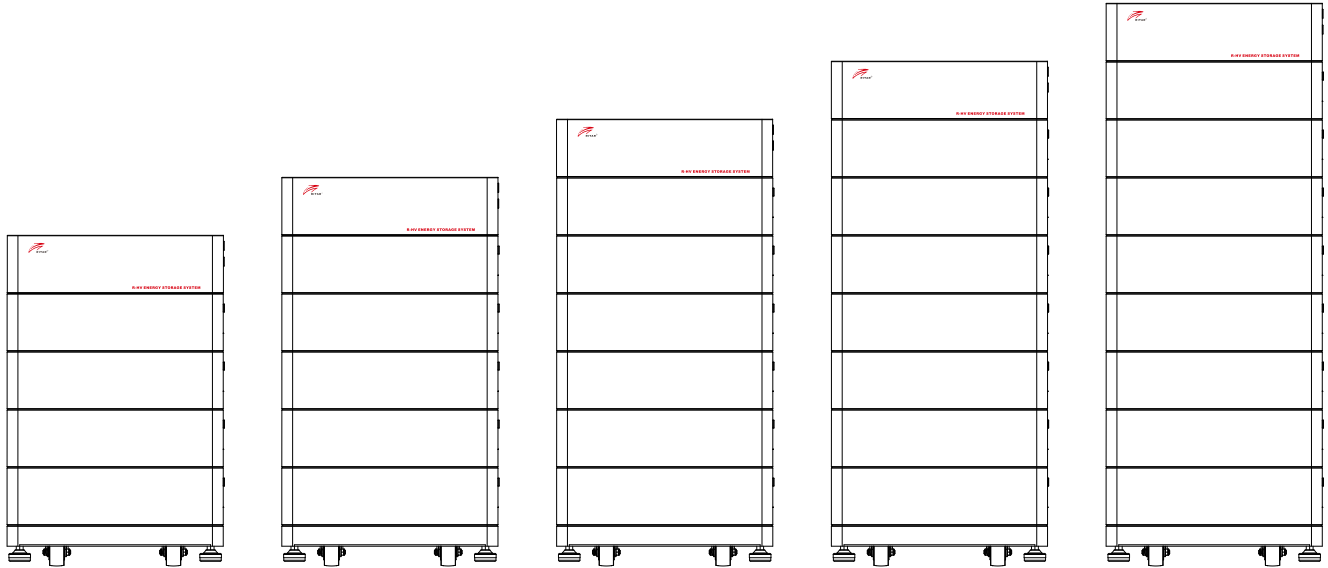

Battery Module	51.2V 100Ah (5.12KWH)				
Number of Battery Modules	4	5	6	7	8
Total Energy [kWh]	20.5	25.6	30.7	35.8	40.9
Nominal Voltage [Vdc]	204.8	256	307.2	358.4	409.6
Voltage Range [Vdc]	160~240	200~300	240~360	280~420	320~480
Max. Charging Current [A]	50	50	50	50	50
Max. Discharging Current [A]	50	50	50	50	50
Pulse Discharge Current	100A/10s	100A/10s	100A/10s	100A/10s	100A/10s
Max Inverter Power [W]	10000	12800	15360	17920	20480
Dimension (W*D*H, mm)	600*450*910	600*450*1070	600*450*1230	600*450*1390	600*450*1550
Operating Temperature Range	Charge: 0 ~ +55°C; Discharge: -20 ~ +55°C				
Operation Humidity	0~95% RH (No condensing)				
Weight [Kg]	Battery Module: 43.7Kg/pcs Base: 16.5Kg/pcs, Top Case: 10.0Kg				
Designed Calendar Life	10 years				
Communication interface	CAN*1, DI *1, DO*2				

DIMENSION

Battery Module

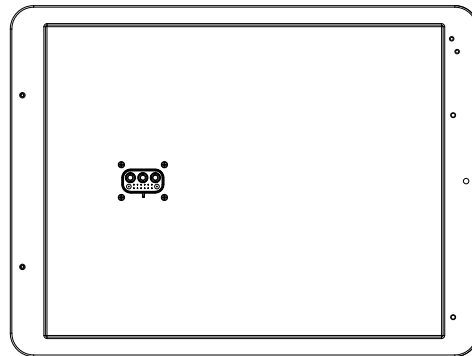
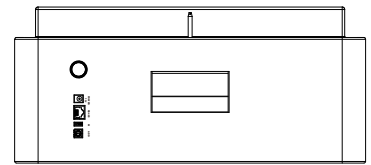
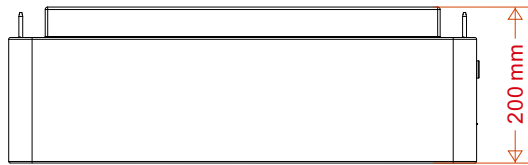
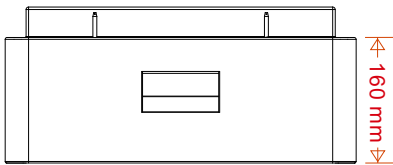
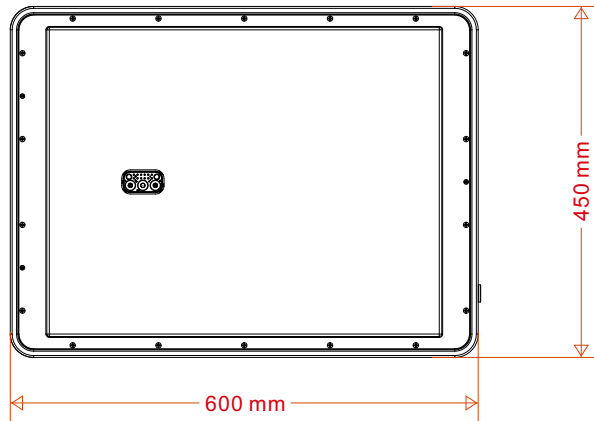

DIMENSION

Top Case

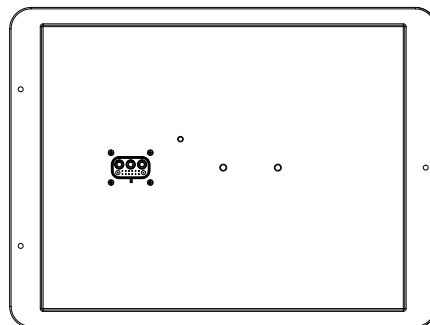
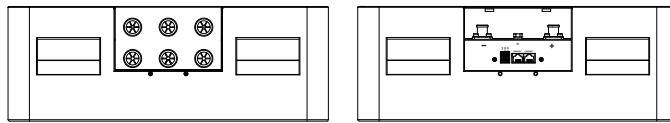
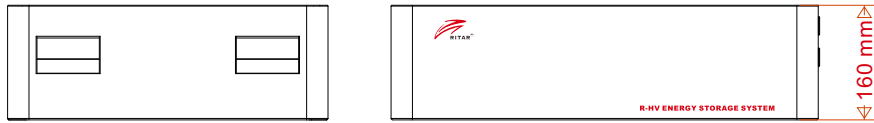
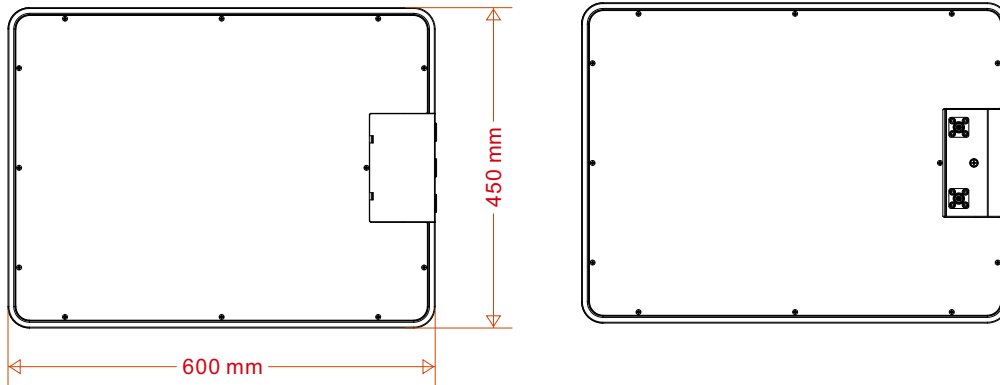

DIMENSION

Base

